

SIGNAL SEQUENCE

| SIGNAL | R/W | LEE HIGHWAY (U.S. 11) | | | | | | | | | | | | TERRACE DRIVE (SOUTH) | | | | | TERRACE DRIVE (NORTH) | | | | | FLASH | | | | | | | | | | | | | | | | | | | | | | | |
|--------|-------|-----------------------|-------|-------|-------|-------|----------|-------|-------|-------|----|-----|-------|-----------------------|----|-----|-------|-------|-----------------------|----|----|-----|-------|-------|-------|-------|-------|----|-----|-------|-------|-------|-------|---|---|---|---|---|---|---|---|---|---|---|---|---|---|
| | | 01-05 | | | | 01-06 | | | | 02-05 | | | | 02-06 | | | | 03 | | | | | 04 | | | | | | | | | | | | | | | | | | | | | | | | |
| | | CLEAR TO | 01-06 | 02-05 | 03 | 04 | CLEAR TO | 01-06 | 02-05 | 03 | 04 | R/W | 02-06 | 03 | 04 | R/W | 01-05 | 01-06 | 02-05 | 03 | 04 | R/W | 01-05 | | 01-06 | 02-05 | 02-06 | 04 | R/W | 01-05 | 01-06 | 02-05 | 02-06 | | | | | | | | | | | | | | |
| 1/6 | <-G/R | <-G/R | <-Y/R | <-Y/R | <-Y/R | <-Y/R | <-Y/R | <-Y/Y | <-Y/Y | <-Y/Y | R | R | R | R | R | R | R | R | R | R | R | R | R | R | R | R | R | R | R | R | R | R | R | R | R | R | R | R | R | R | R | R | R | R | R | R | R |
| 2 | R | R | R | R | R | R | R | R | R | R | R | R | R | R | R | R | R | R | R | R | R | R | R | R | R | R | R | R | R | R | R | R | R | R | R | R | R | R | R | R | R | R | R | R | R | R | R |
| 2/5 | <-G/R | <-Y/R | <-Y/R | <-Y/R | <-Y/R | <-G/G | <-Y/G | <-Y/Y | <-Y/Y | <-Y/Y | R | R | R | R | R | R | R | R | R | R | R | R | R | R | R | R | R | R | R | R | R | R | R | R | R | R | R | R | R | R | R | R | R | R | R | R | R |
| 3 | R | R | R | R | R | R | R | R | R | R | R | R | R | R | R | R | R | R | R | R | R | R | R | R | R | R | R | R | R | R | R | R | R | R | R | R | R | R | R | R | R | R | R | R | R | R | R |
| 3/5 | R/G-> | R/Y-> | R/Y-> | R/Y-> | R/Y-> | R/G-> | R/Y-> | R/Y-> | R/Y-> | R/Y-> | R | R | R | R | R | R | R | R | R | R | R | R | R | R | R | R | R | R | R | R | R | R | R | R | R | R | R | R | R | R | R | R | R | R | R | R | R |
| 4 | R | R | R | R | R | R | R | R | R | R | R | R | R | R | R | R | R | R | R | R | R | R | R | R | R | R | R | R | R | R | R | R | R | R | R | R | R | R | R | R | R | R | R | R | R | R | R |
| 4 | R | R | R | R | R | R | R | R | R | R | R | R | R | R | R | R | R | R | R | R | R | R | R | R | R | R | R | R | R | R | R | R | R | R | R | R | R | R | R | R | R | R | R | R | R | R | R |
| 6 | R | R | R | R | R | R | R | R | R | R | R | R | R | R | R | R | R | R | R | R | R | R | R | R | R | R | R | R | R | R | R | R | R | R | R | R | R | R | R | R | R | R | R | R | R | R | R |
| 6R | R | R | R | R | R | R | R | R | R | R | R | R | R | R | R | R | R | R | R | R | R | R | R | R | R | R | R | R | R | R | R | R | R | R | R | R | R | R | R | R | R | R | R | R | R | R | R |

SIGNAL PHASING

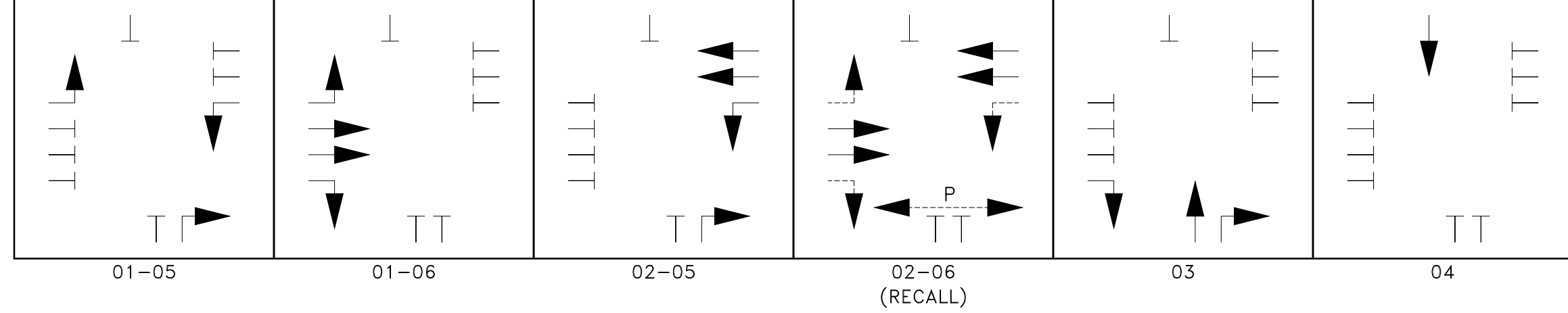

THESE PLANS ARE UNFINISHED AND ARE NOT TO BE USED FOR ANY TYPE OF CONSTRUCTION.



CITY OF
BRISTOL, VIRGINIA
300 LEE STREET
BRISTOL, VA 24201
(276) 645-7470

| | |
|-----------|--|
| REVISIONS | |
| DATE | |



**WIDENING OF
LEE HIGHWAY
PHASE - 2**
UPC 105753

**SIGNALIZATION PLANS
LEE HWY & CASCADE DR
LEE HWY & ALEXIS DR**

DATE: MAY 5, 2017
DRAWING NO. T30-229
FILE NAME: LEE HWY PH 2

SHEET NUMBER
6.2 OF 11

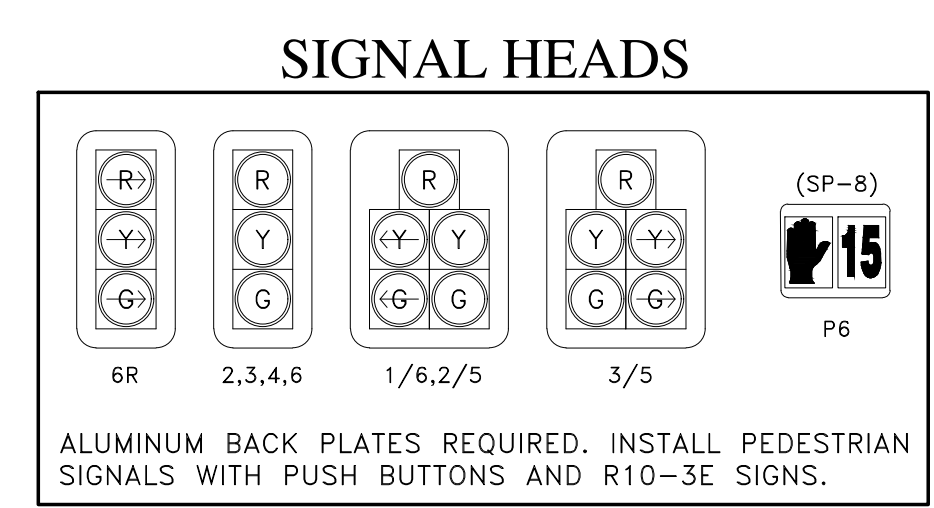
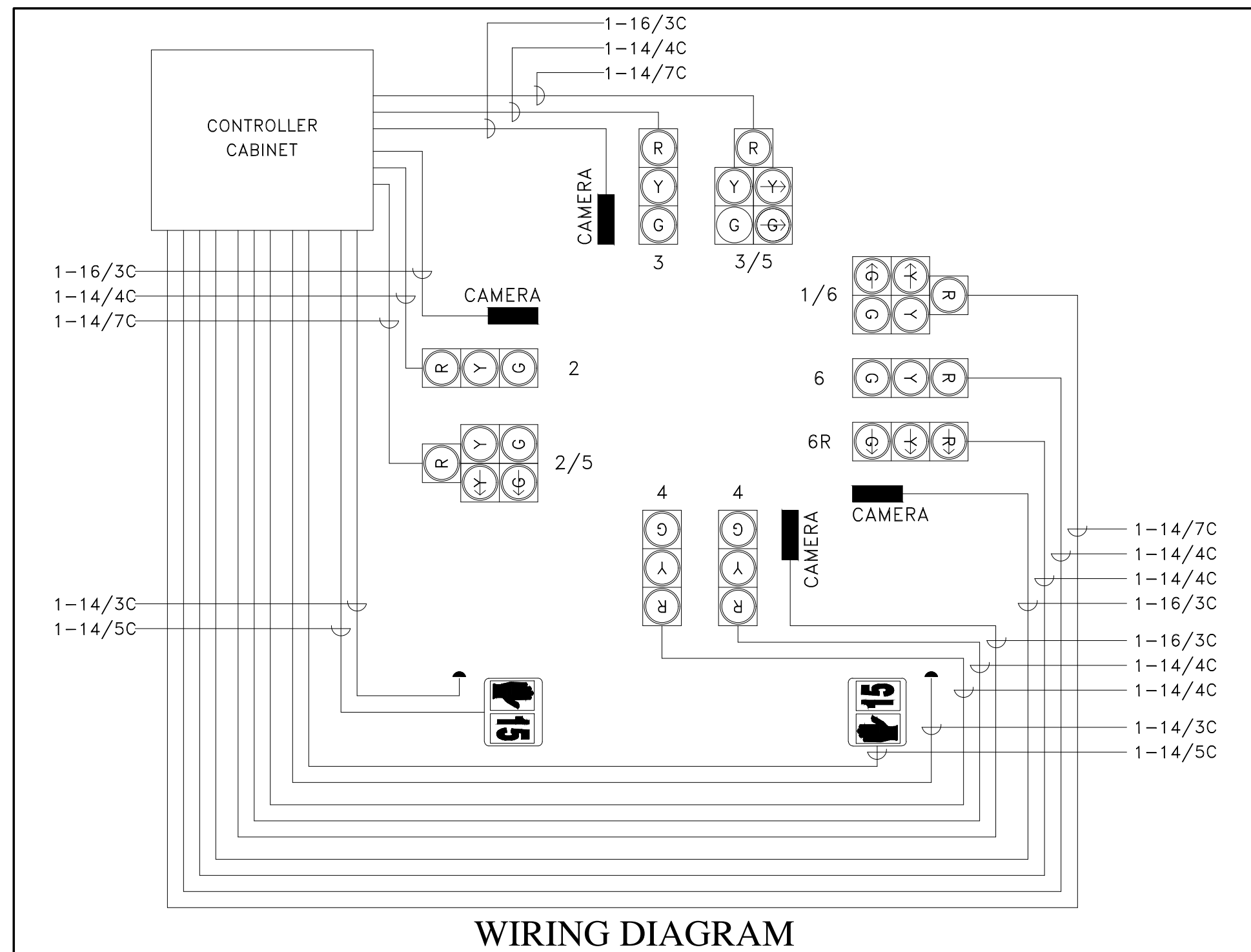

- △ CONTROL CABINET
- △ VDOT STD SE-3 ELECTRICAL SERVICE W/ METER BASE & VDOT STD JB-S1 JUNCTION BOX
- △ VDOT STD SE-6 ELECTRICAL SERVICE W/ METER BASE & VDOT STD JB-S1 JUNCTION BOX
- △ VDOT STD JB-S2 JUNCTION BOX
- △ VDOT STD JB-S3 JUNCTION BOX

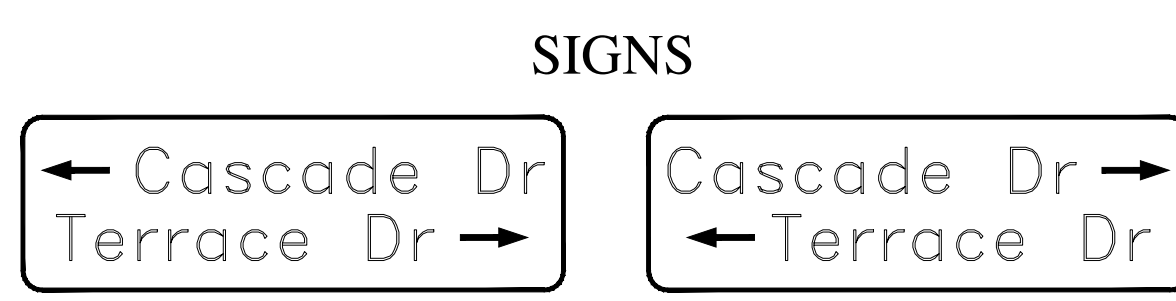
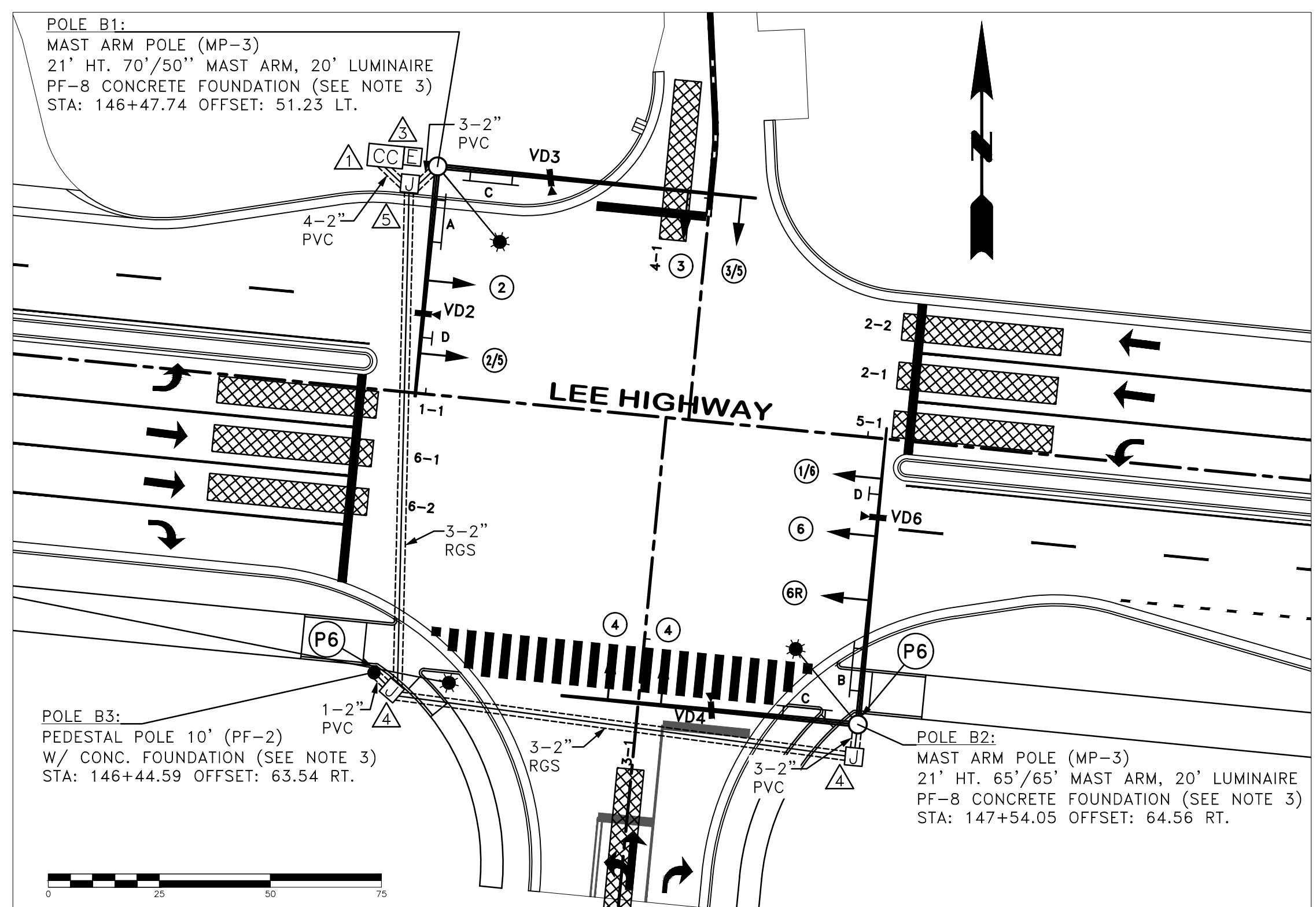
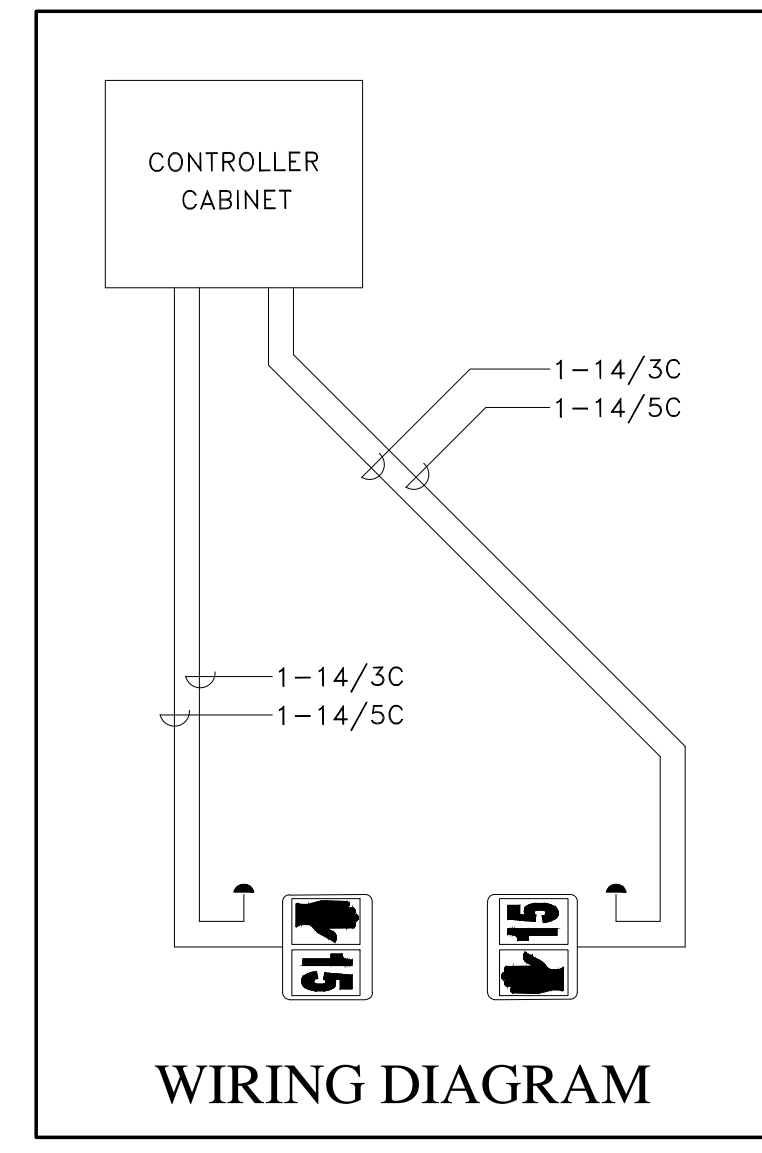

Lee Highway 2750

STREET SIGNS TO HAVE 12" HIGH LETTERING, NUMBER TO BE 6" HIGH, 6" SPACE BETWEEN LETTERS AND EDGE OF SIGN.

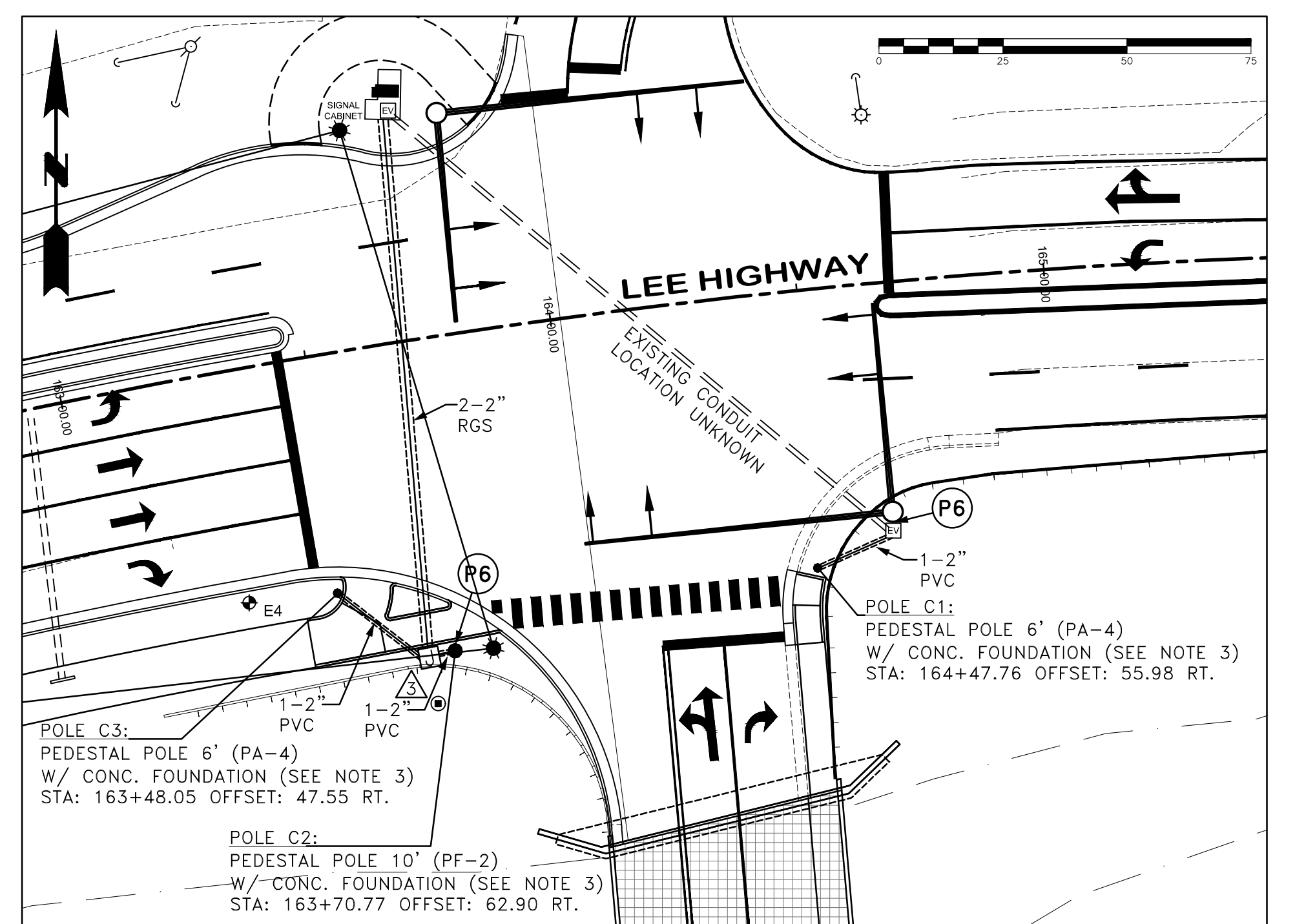
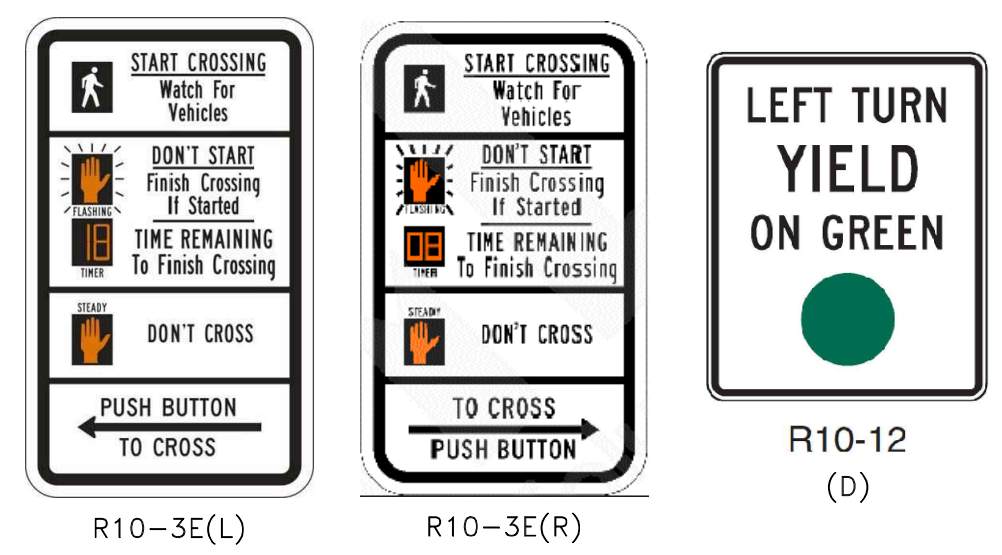

LEE HIGHWAY & ALEXIS DRIVE